

CENTRO ECOLÓGICO DE EDUCAÇÃO AMBIENTAL

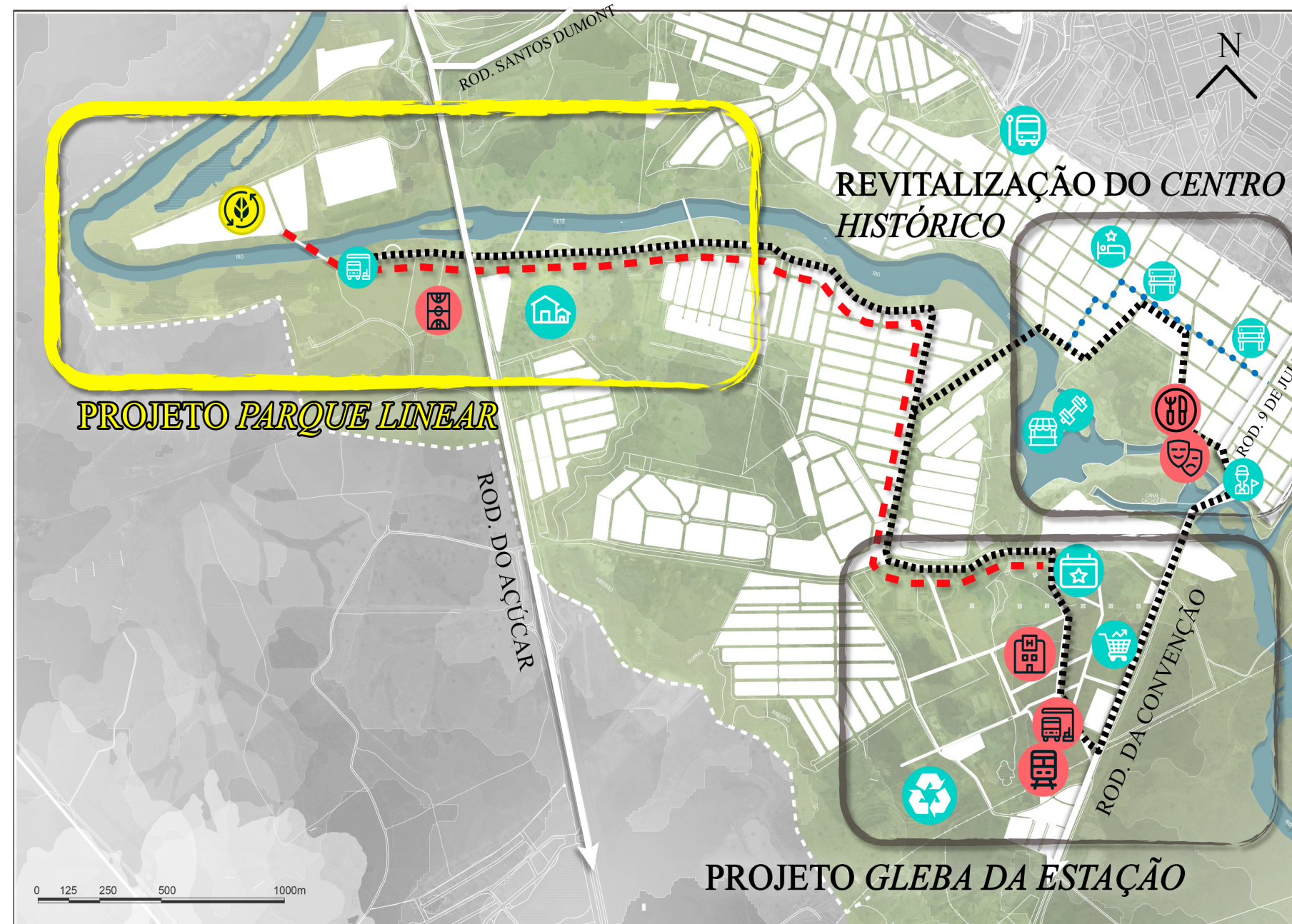

- CENTRO ECOLÓGICO
- COMPLEXO ESPORTIVO
- CENTRO GASTRONÔMICO
- HOTEL
- TERMINAL INTERMODAL
- CENTRO CULTURAL
- PARADA DO ÔNIBUS TURÍSTICO
- CONJUNTO HABITACIONAL
- TERMINAL DE ÔNIBUS
- POUSADA
- PARKLET
- ACADEMIA AO AR LIVRE
- QUIOSQUE
- CENTRO DE APOIO AO TURISTA
- ESPAÇO PARA EVENTOS
- CENTRO COMERCIAL
- ATIVAÇÃO DA LINHA DO TREM
- ATERRO SANITÁRIO

Mapa de Análise do Existente



- RODOVIA
- VIA COLETORA
- LOTES
- APP
- DISTRITO INDUSTRIAL
- PARQUE DO LAGO
- OCUPAÇÃO IRREGULAR

Mapa de Análise da Proposta



- PONTE DE CONEXÃO
- FLUXO PRIVADO
- FLUXO COLETIVO
- RODOVIA
- APP
- DISTRITO INDUSTRIAL
- PARQUE DO LAGO
- OCUPAÇÃO IRREGULAR
- ÁREA DE PROJETO
- REALOCAÇÃO DE INDÚSTRIAS



Perspectiva 1

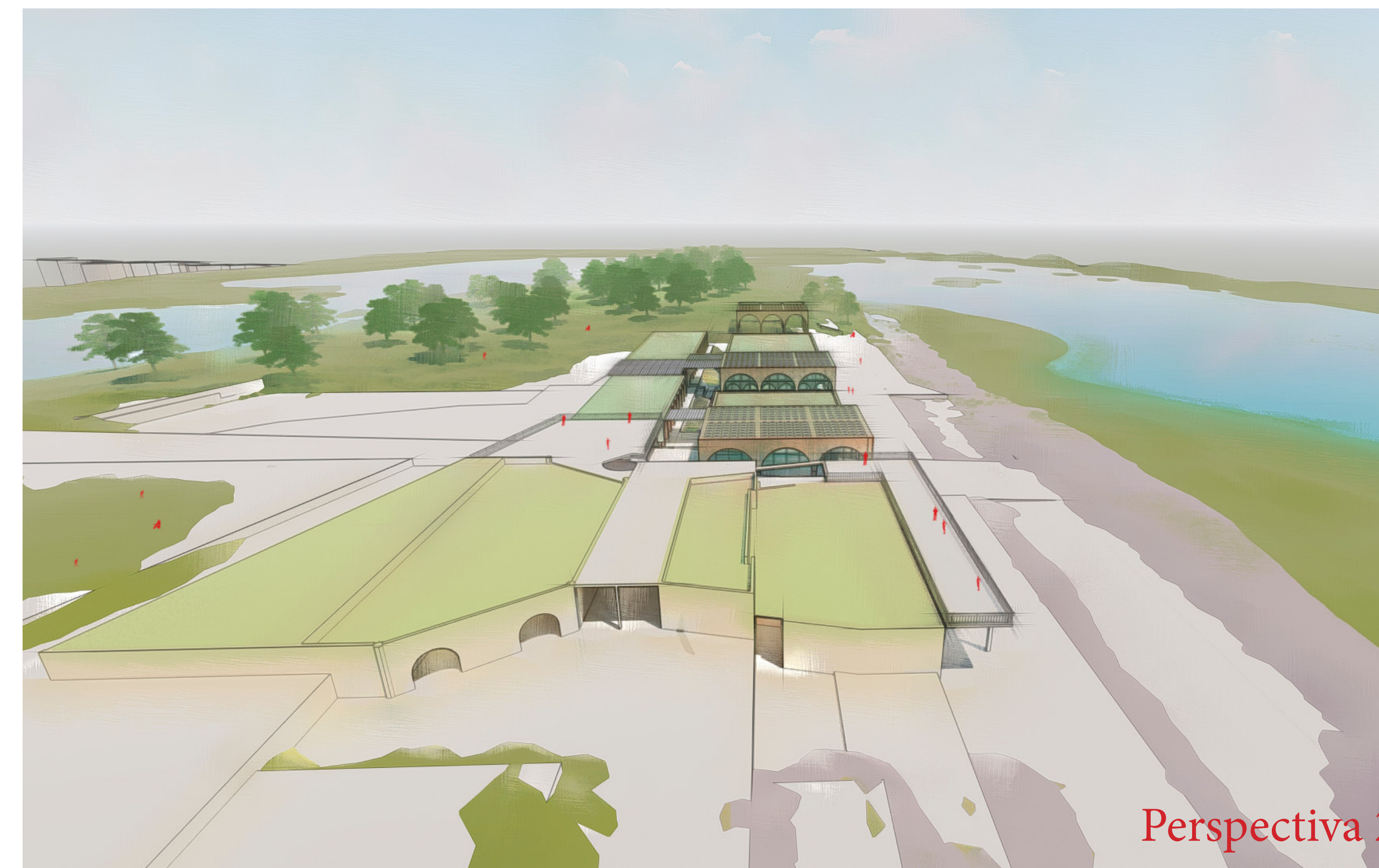

Perspectiva 2

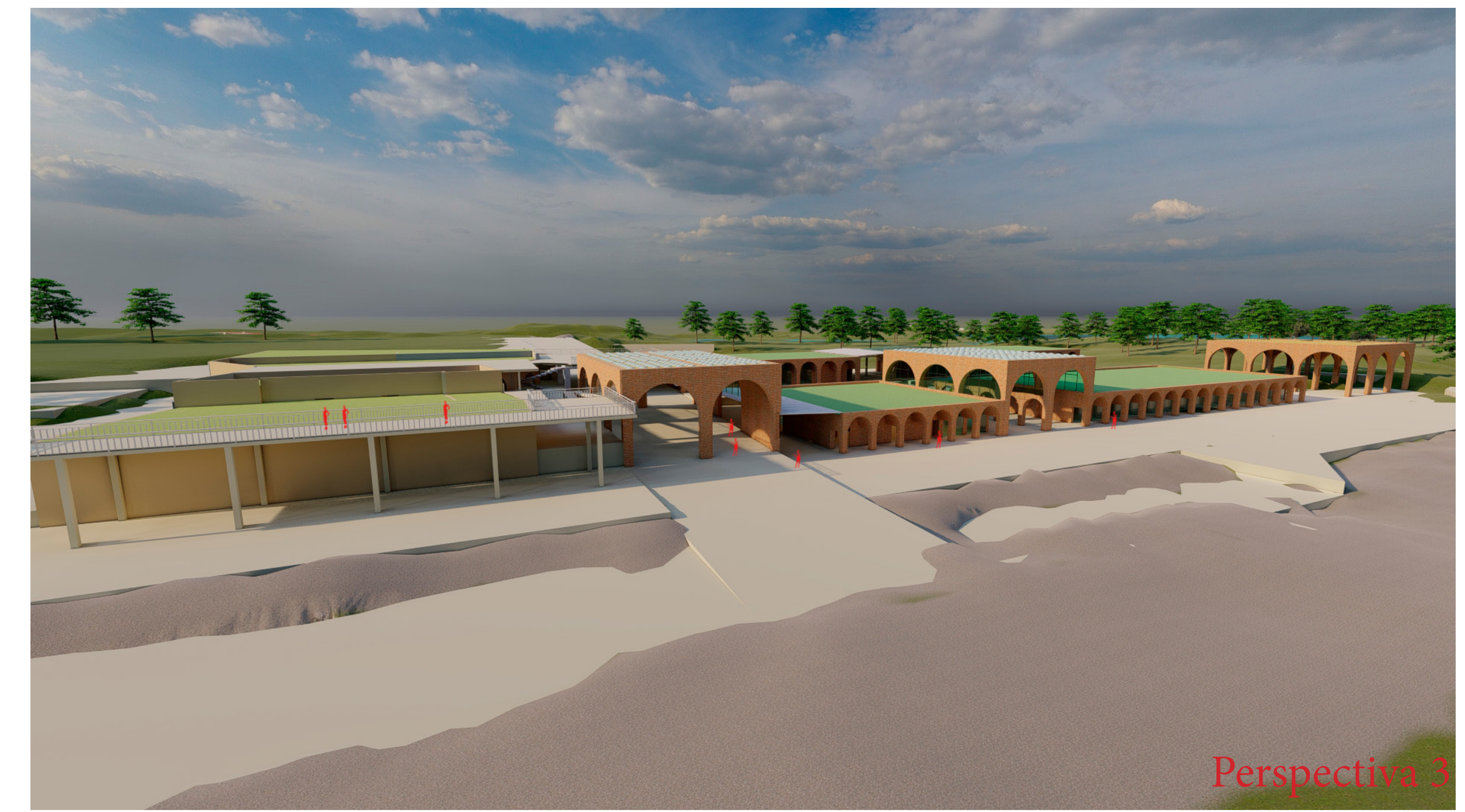

Perspectiva 3

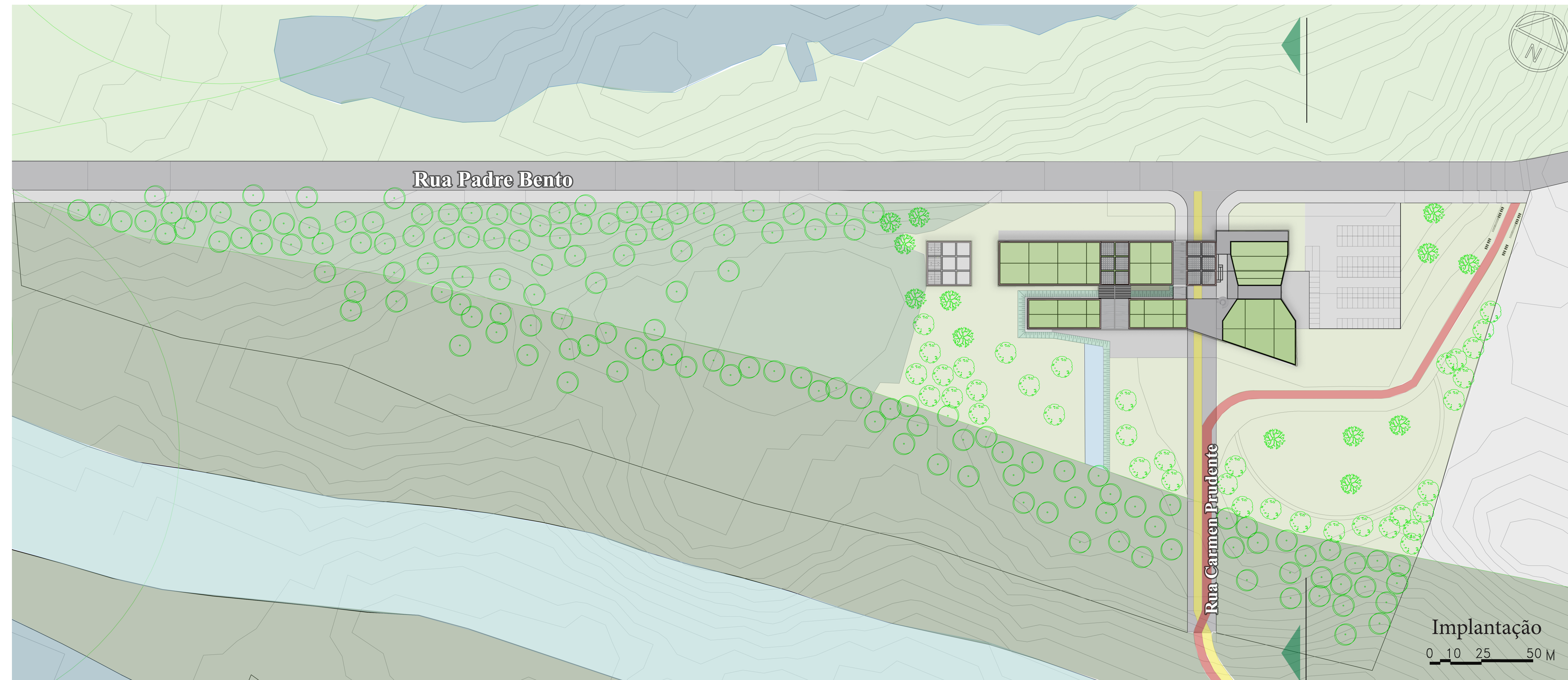

- PROPOSTA DE REFLORESTAMENTO
- REVITALIZAÇÃO DAS MARGENS DE APP
- GRAMADO E ARBUSTIVAS
- CONTINUIDADE ACESSO PEDESTRES
- CICLOVIA



CENTRO ECOLÓGICO DE EDUCAÇÃO AMBIENTAL

SALTO: UM OLHAR PARA O RIO

Plano de Reestruturação YTU para Estância Turística de Salto (SP) GUAÇU

TFG 2022



Perspectiva 4



Perspectiva 6



Perspectiva 5



Perspectiva 7

Mapa de Acessos e Fluxos:

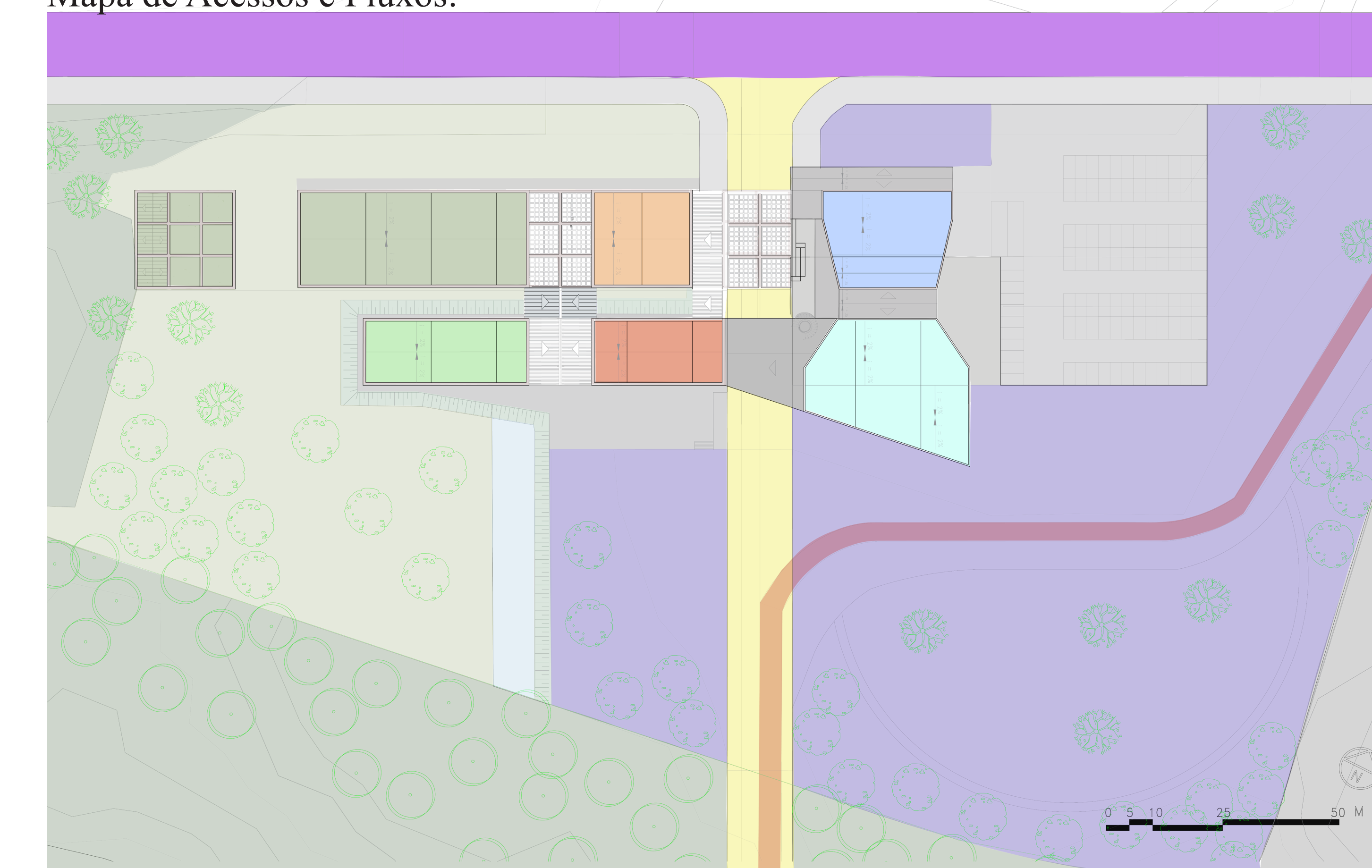

- VIA PASSAGEM DE CARROS
- VIA DE PEDESTRES
- CICLOVIA
- ÁREA PÚBLICA
- ADMINISTRATIVO
- SERVIÇOS
- LABORATÓRIOS E ESTUFA
- ALOJAMENTOS
- GALERIA DE EXPOSIÇÕES E BIBLIOTECA
- AUDITÓRIO

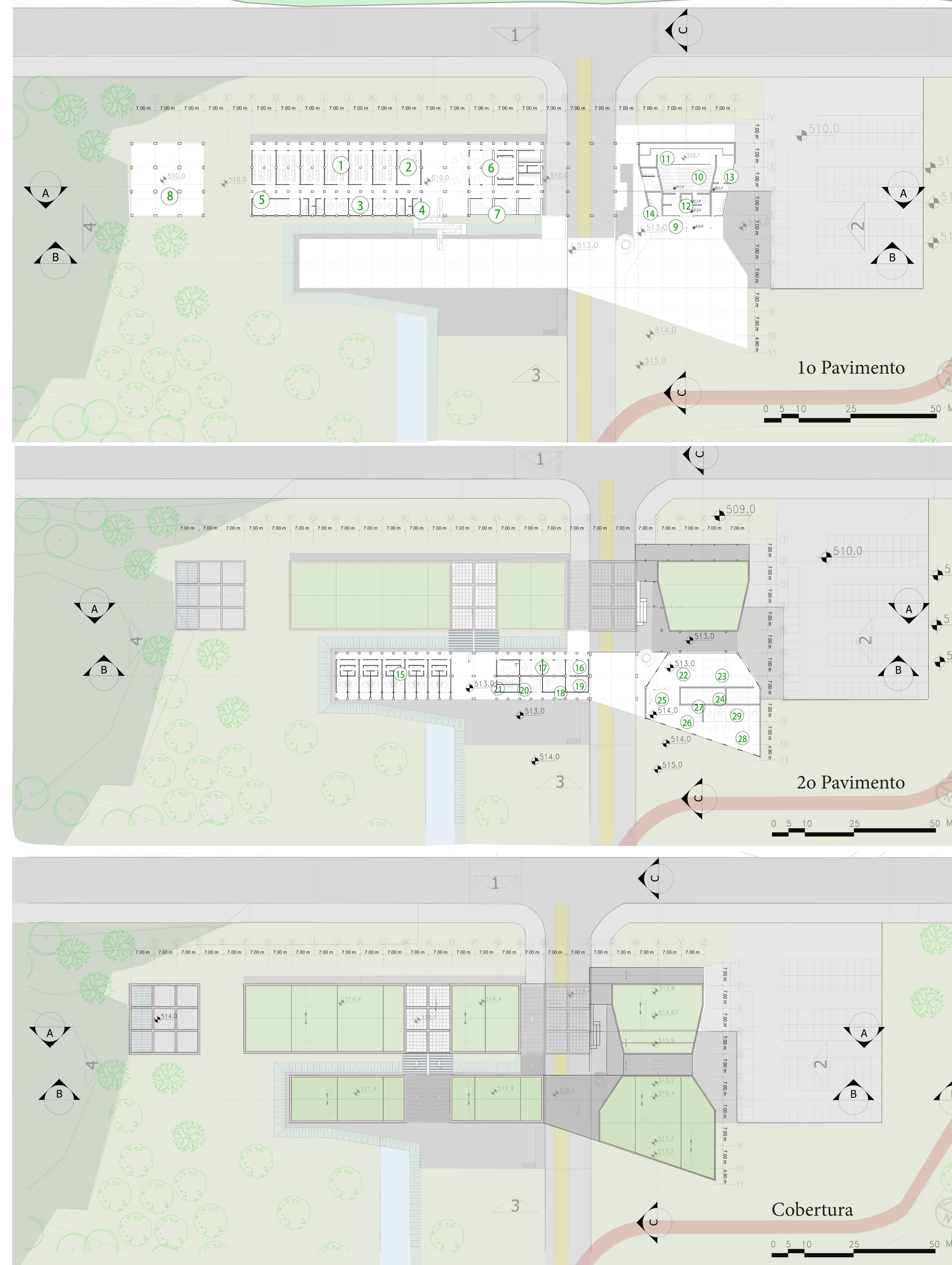

- 1 LABORATÓRIOS 318 m²
- 2 CENTRO ACADÊMICO 53 m²
- 3 SALA REUNIÕES 90 m²
- 4 BANHEIROS 90 m²
- 5 ALMOXARIFADO 56 m²
- 6 LANCHONETES 106 m²
- 7 CONVENIÊNCIAS 90 m²
- 8 ESTUFA 441 m²
- 9 FOYER 13 m²
- 10 PLATEIA 106 m²
- 11 PALCO 66 m²
- 12 AUDIOVISUAL 13 m²
- 13 CAMARINS 36 m²
- 14 BANHEIROS 72,35 m²
- 15 ALOJAMENTOS 330 m²
- 16 SECRETARIA 36 m²
- 17 SALA REUNIÕES 90 m²
- 18 DIRETORIA 36 m²
- 19 ALMOXARIFADO 36 m²
- 20 COPA/ COZINHA 35 m²
- 21 BANHEIRO 30 m²
- 22 EXPOSIÇÃO TEMPORÁRIA 87,5 m²
- 23 EXPOSIÇÃO PERMANENTE 158 m²
- 24 DEPÓSITO 81,5 m²
- 25 HALL 35 m²
- 26 SECRETARIA 18 m²
- 27 FUNCIONÁRIO 17 m²
- 28 SALA REUNIÕES 90 m²
- 29 ÁREA DE LEITURA/ LEITURA AO AR LIVRE 158 m²

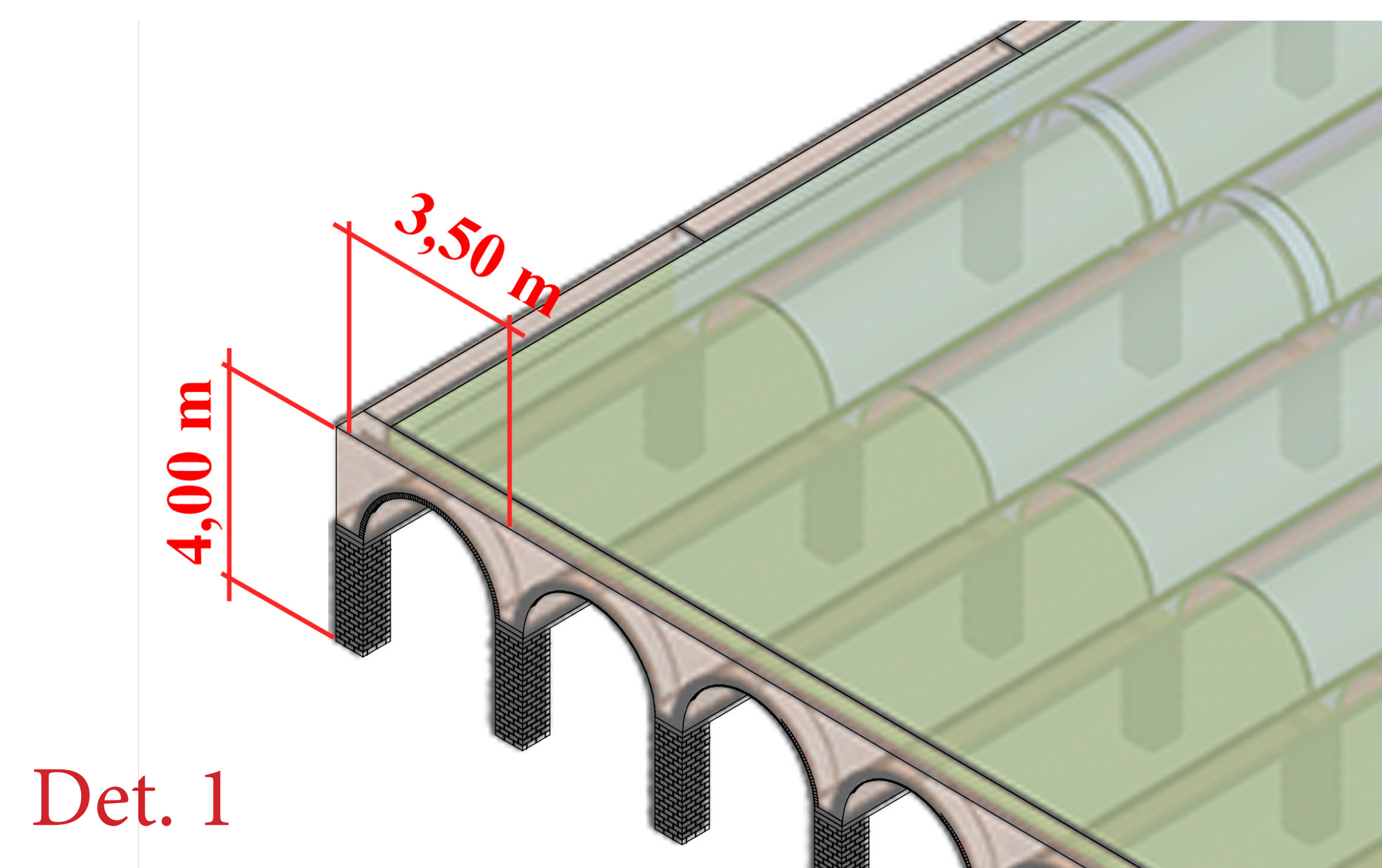
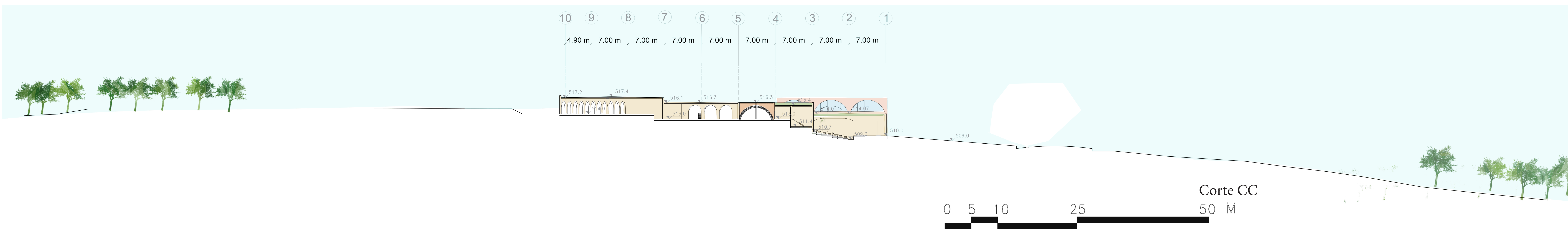
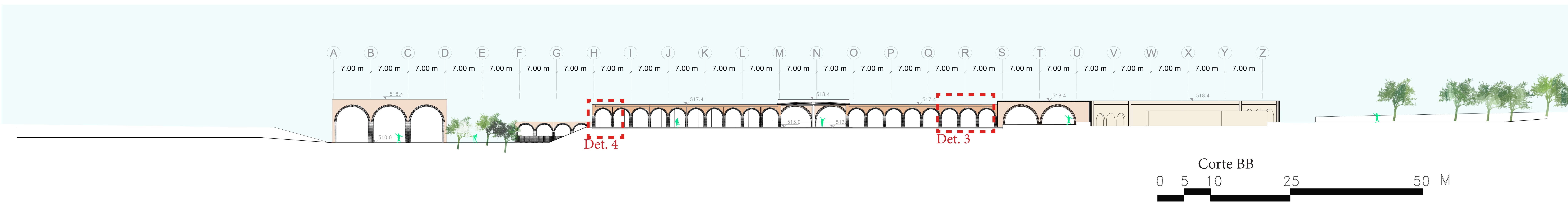
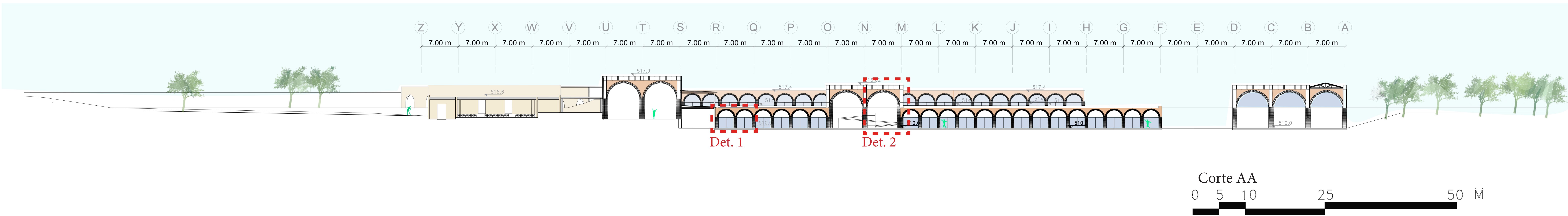

Det. 1

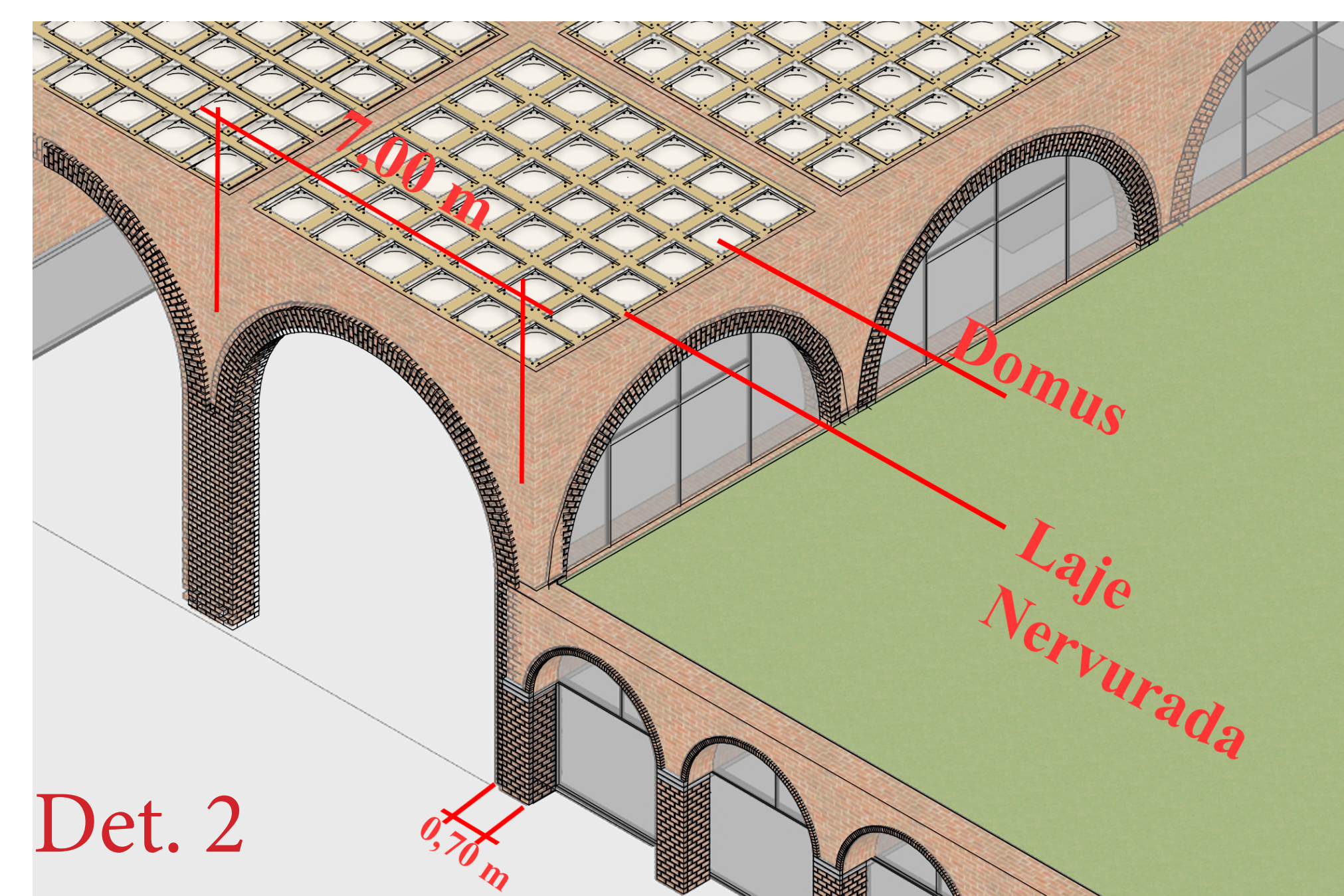

Det. 2

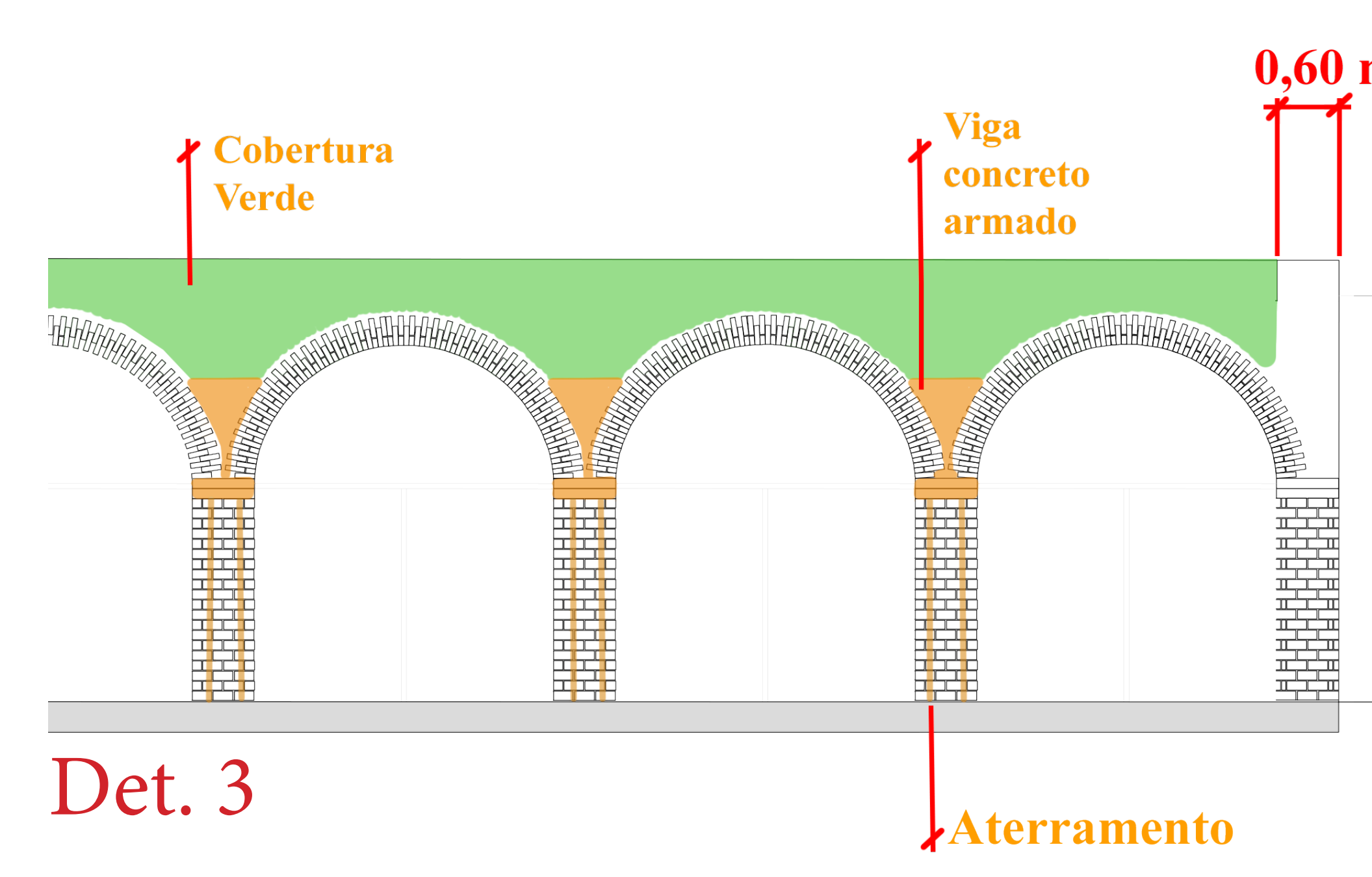

Det. 3

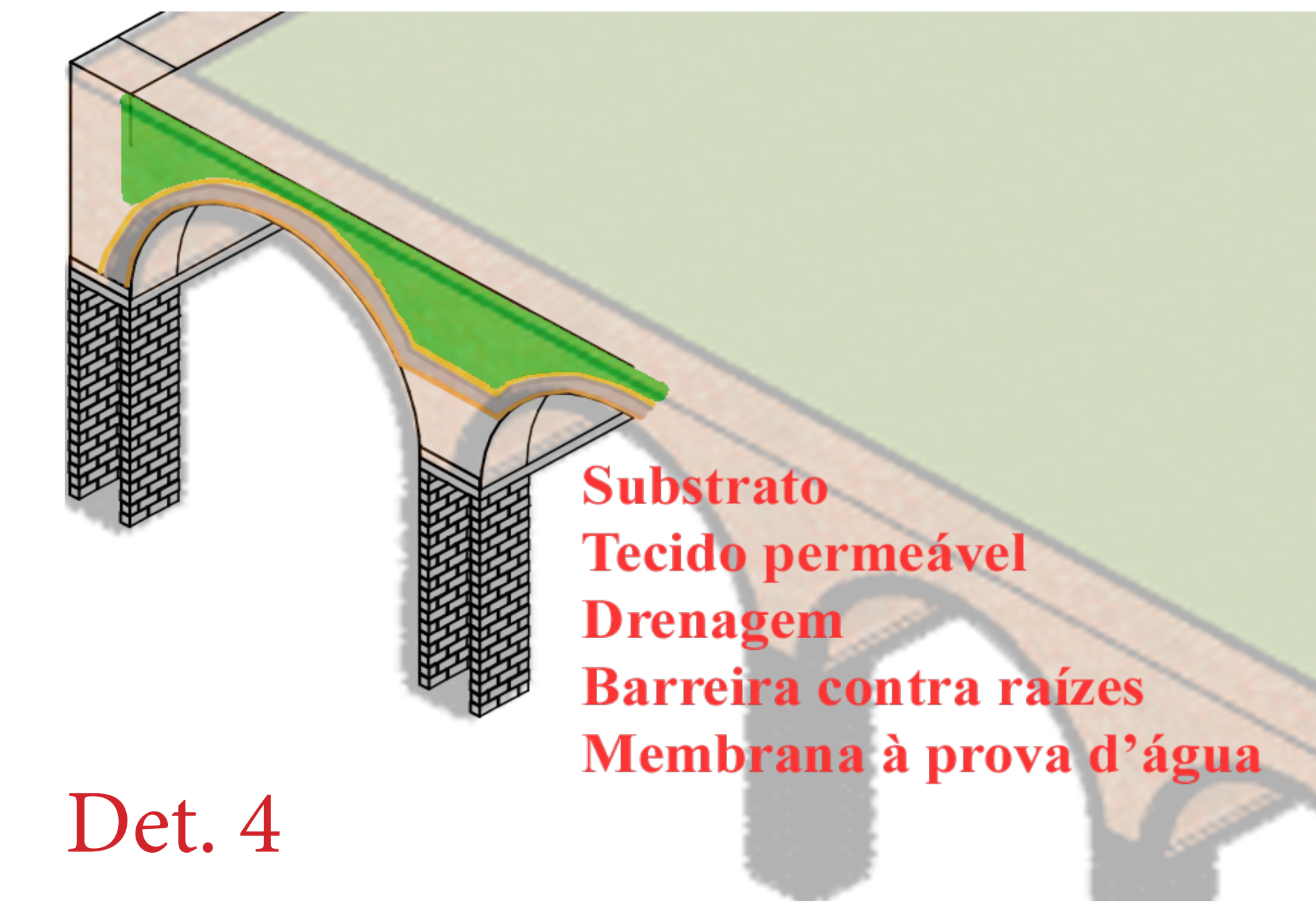

Det. 4

